

## High Performance

- / The maintenance-free, high-power, brushless AC traction motor has excellent acceleration, performance, good climbing ability, and low heat generation.
- / The CURTIS control system provides accurate, stable, and more efficient control of the AC traction motor.
- / The CAN-BUS structure makes the communication between the different parts on the truck faster and more reliable.
- / The truck uses the regenerative braking system to prevent the pallet truck from sliding down a ramp.
- / The switches, controller, connectors, and battery plug are all parts from industry known suppliers to ensure reliability, performance, and ease of service.

## Reliability

- / With a high-strength steel frame structure, the truck's frame has a large residual load capacity and a long service life.
- / The electrical system uses waterproof connectors and protection on the wires and cables to improve the electronic's reliability.
- / The unique floating suspension system ensures that the drive wheels grip and provide smooth operation.
- / The pump motor has a longer service life and saves energy because of the electronic lifting limit switch on the motor.
- / The low noise and vibration hydraulic power unit enables stable and reliable lifting and lowering.
- / The punched formed forks provide higher strength and are impact resistant.
- / The pallet truck is equipped with tip guides to improve operational efficiency.
- / The H-type mast profile section provides better load stability.
- / The power plug is fixed on the pallet truck's body to avoid damage when installing the battery.
- / The new design drive system prevents the drive motor from accompanying the tiller's rotation. This keeps all of the drive motor's cable connections from bending.
- / Using a non-contact proximity switch provides reliable operation and a longer service life.

## Maintenance

- / The brushless AC drive motor is maintenance-free. This significantly reduces the operating costs of the pallet truck.
- / The maintenance hatch opens to allow for easy access to all of the truck's components.
- / The shafts are equipped with lubricated sleeves and oil cups to facilitate maintenance and promote a long service life.

## Comfort

- / The floating suspension driving system automatically adjusts depending on the load to provide sufficient power to the driving wheels.
- / Thanks to the tiller's design, all operations can be completed with one hand.
- / When in turtle mode, the truck can be driven slow easily, and more accurately.
- / The pallet truck's design is optimized for great visibility and easy operation in narrow aisle applications.
- / Customer can choose a variety of different lengths and outside fork widths to fit their needs.

## Safety

- / The A Series Pallet Jack features three braking types. These include releasing, reversing, and emergency braking. This ensures the operators safety.
- / The pallet jack won't slip on a grade to ensure safe operation.
- / When pressed, the emergency button on the tiller head immediately cuts power to the pallet truck to help keep the operator safe.
- / The lifting limit switch is designed to help protect loads from damage.

## Standard Specification

- / Horn
- / AC Drive Motor
- / PU Drive Wheel
- / Single Load Wheel
- / Caster Wheel
- / 48" Fork Length
- / 27" Outside Fork Width
- / CURTIS AC Controller
- / Hydraulic Power Unit
- / Electronic Lifting Limitation
- / Emergency Disconnect Switch
- / Multi-Function Battery Indicator
- / CAN-BUS System Multi-Function Tiller

## Options

- / Different Fork Lengths Available
- / Different Outside Fork Widths Available
- / Tandem Load Wheels
- / Freezer Package
- / Pallet Entry Roller
- / Load Backrest
- / External Charger
- / Pin Code Access



**HANGCHA**

**HC FORKLIFT AMERICA CORPORATION**

**Company address:**  
10405-A Granite Street  
Charlotte, NC 28273

Toll Free: (888) 652-8395  
Phone: (980) 888-8335  
Fax: (980) 888-8336

america@hcforklift.com  
www.hcforkliftamerica.com



2022 VERSION 1/01/2022

HANGCHA GROUP CO., LTD. reserves the right to make any changes without notice concerning colors, equipment, or specifications detailed in this brochure, or to discontinue individual models. The colors of trucks, delivered may differ slightly from those in brochures.

# A Series Lithium-ion Walkie Pallet Jack

with capacities of 6,000lbs

**Making Material Handling Easier**  
SINCE 1956





# LITHIUM POWER



## INNOVATIVE SOLUTIONS NEW POWER NOW

Lithium-ion technology (Lithium Iron-Phosphate), was developed jointly by HANGCHA and CATL for use in material handling equipment applications. These innovative and reliable battery cells and modules are manufactured to the highest standard by CATL exclusively for HANGCHA's forklift line.

- / **Battery Technology:** We use square lithium iron phosphate batteries. These are the same type of batteries used in new electric vehicles.
- / **Design:** The module uses a sturdy and lightweight aluminum alloy frame. It is also designed to provide excellent heat dissipation.
- / **Safe and Effective:** Charging efficiency as high as 98% and the thermal runaway temperature is at 600 °C and above.
- / **Adapted to Low Temperatures:** Comes standard with an electrical heating feature, ensuring normal operation in low temperatures.
- / **Quick Charging:** Fully charges in 2 hours.
- / **Efficient:** Can use opportunity charging to allow for continuous use in multi-shift operations.
- / **Long-Lasting:** 4000 charging cycles with a capacity retention greater than 80%.
- / **Maintenance-Free:** Lithium-ion batteries do not require manual maintenance such as watering.
- / **Green and clean:** The batteries are pollution-free, release zero emissions, and are recyclable.

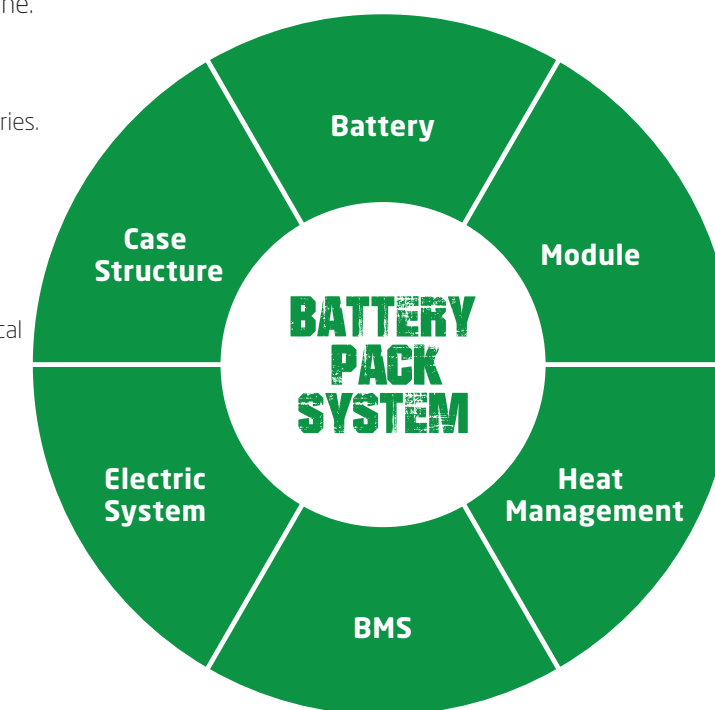

### CATL Lithium Iron Phosphate Battery Pack

- / Integrated Battery Management System (BMS) continually monitors energy management and ensures reliable operation.
- / HANGCHA provides these Lithium Iron Phosphate (LiFePO<sub>4</sub>) battery packs with up to a 5 year or 10,000 hour warranty.
- / See warranty certificate for specific warranty information on the Lithium Iron Phosphate battery packs.

Standard Battery Capacity	
Battery Capacity (V/Ah)	24V/202Ah
	5.02kW-h

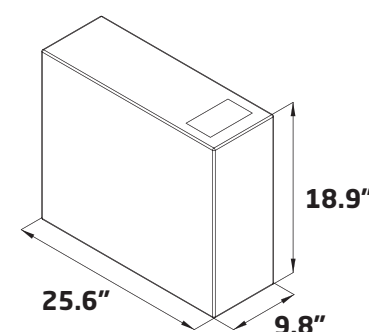

### RAPID CHARGING

Li-Ion  
2 hours  
100%

Lead-acid batteries  
8-10 hours 100%

**Rapid and opportunity charging ensure continuous availability of material handling equipment**

The chargers allow for fast full charging or boost charging (100 % charge in 2 hours). The lithium-ion batteries are maintenance free and do not require a battery change when used in multi-shift operations. Instead, the batteries can be charged during user breaks and shift changes which allows the forklift to continuously run during multi-shift operations.

### A Series Lithium-ion Walkie Pallet Jack

Distinguishing Marks	1.1	Manufacturer	HANGCHA GROUP CO.,LTD.	
		HCFA Model Number	WP390L	
	1.2	Manufacturer's Type Designation	CB030-AC2-I	
	1.4	Operator Type: hand, pedestrian, standing, seated, order-picker	Pedestrian	
	1.5	Rated Capacity/Rated Load	Q (lb/kg)	6000/2721
Weight	1.6	Load Centre Distance	c (in/mm)	24/600
	1.9	Wheelbase	y (in/mm)	53.4/1357 <sup>1)</sup>
Tires & Chassis	2.1	Service Weight	lb/kg	1265/574
	3.1	Tires: solid rubber, superelastic, pneumatic, polyurethane		PU
Dimensions	3.2	Tire Size, front		Φ230x75Φ9.1x3.0
	3.3	Tyre Size, rear		Φ85x70Φ3.3x2.8
	3.4	Additional Wheel (dimensions)		Φ100x40Φ3.9x1.6
	3.5	Wheels, number front / rear (x = driven wheels)		1x+2/4
	3.6	Tread, front	b <sub>10</sub> (in/mm)	18.9/480
	3.7	Tread, rear	b <sub>11</sub> (in/mm)	14.6/370
	4.4	Lift	h <sub>3</sub> (in/mm)	4.9/125
	4.15	Fork Height, lowered	h <sub>13</sub> (in/mm)	3.35/85
	4.19	Overall Length	l <sub>1</sub> (in/mm)	70.1/1781
	4.21	Overall Width	b <sub>1</sub> (in/mm)	29.5/750
	4.22	Fork Dimensions ISO 2331	s/e/l (in/mm)	2.5/6.7/48 (64/170/1220)
	4.25	Distance between Fork-Arms	b <sub>5</sub> (in/mm)	22/27 (540/680)
	4.32	Ground Clearance, center of wheelbase	m <sub>2</sub> (in/mm)	0.98/25
	4.34.1	Aisle Width for Pallets 39" x 47" Crossways	Ast (in/mm)	77/1955 <sup>2)</sup>
	4.34.2	Aisle Width for Pallets 31.5" x 47" Lengthways	Ast (in/mm)	78.9/2005 <sup>2)</sup>
Performance Data	4.35	Turning Radius	Wa (in/mm)	62.4 (1585 <sup>1)</sup> )
	5.1	Travel Speed, laden/unladen	mph (km/h)	3.1/3.7 (5.0/6.0)
	5.2	Lift Speed, laden/unladen	ft/min (m/s)	7.1/10.0 (0.036/0.051)
Electric Motor	5.3	Lowering Speed, laden/unladen	ft/min (m/s)	11.8/10.8 (0.060/0.055)
	5.8	Max. Gradeability, laden/unladen	%	6/20
	6.1	Drive Motor Rating S2 60 min	kW	1.5/2.0
	6.2	Lift Motor Rating at S3 15%	kW	2.2/3.0
	6.4	Battery Voltage, rated capacity	V/Ah	24/202
8.1	Type of Drive Control	V/Ah	AC	
9.1	Manufacturer		CURTIS	

Note: 1) When fork lowered, add 2.68in or 68mm. 2) When fork lowered add 1.57in or 40mm.

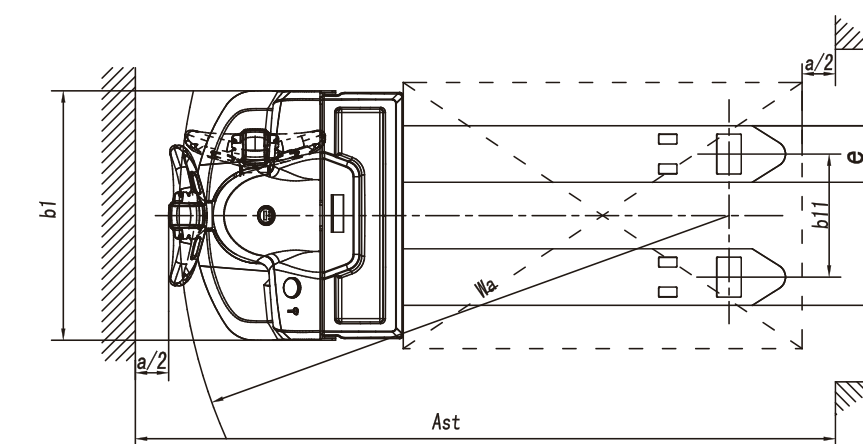
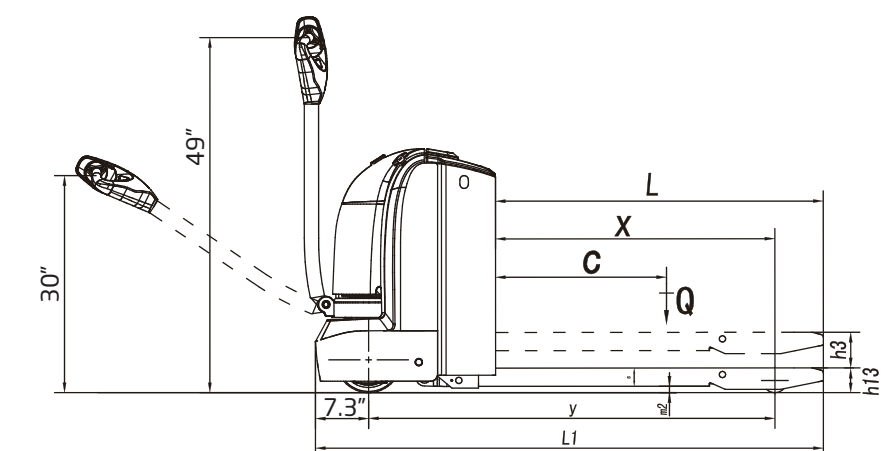

HANGCHA provides Li-Ion battery (LiFePO<sub>4</sub>) with 5 years or 10000 hours warranty.

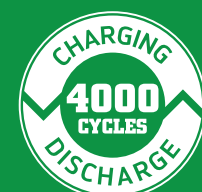

5 YEARS WARRANTY