

# STM Series - 4 WAY truck mounted forklift

## 5500 lbs capacity @ 24" load centre



### Standard specifications

The SELLICK STM 4WAY multi-directional truck mounted forklift provides traditional forward and rearward operation plus the ability to transition sideways to transport long loads in narrow spaces. The transition from standard mode to 4 way mode is quick and smooth with the simple flick of a switch. The onboard LCD display assists the operator with the travel mode change. Pantograph reach model (STM55P-4W) increases efficiency by allowing the operator to load and unload from the same side of the truck or trailer.

### Engine

- KOHLER® KDI 1903TCR Tier 4, direct injection, electronic, 3 cylinder diesel engine requires NO exhaust aftertreatment.
- Diesel Particulate Filter (DPF) and Diesel Exhaust Fluid (DEF) are not required reducing operating costs.
- 56 hp at 2,600 rpm.
- Torque rating 166ft. lbs @ 1,500 rpm.
- Water separator.
- Cold weather starting aid.
- Fuel capacity: 9 gallons (34 L).

### Transmission

- Hydrostatic transmission.
- Full-time 3-wheel drive.
- Inching control for precise load placement.

### Operator Compartment

- Side-mount operator station provides increased visibility over loads of all sizes.
- Meets or exceeds ANSI/ITSDF B56.14 FOPS/ROPS standard.
- Adjustable driver's seat with retractable seatbelt.
- Automotive style controls.
- Latched operator's manual compartment.
- Safety decal package.

### Instrumentation

- Multi-function LCD Display includes: fuel level, engine coolant temperature, system voltage, rpm and hour reading.
- On-screen assisted transitioning between standard and 4 way modes.
- One button transitioning between standard and 4 way modes.
- On-board diagnostics providing just in time troubleshooting of performance and maintenance related issues.
- Cold start engine protection with neutral safety start.
- Horn, back up alarm.

### Hydraulics

- 5-spool hydraulic valve with easy-to-reach controls.
- Stabilizers.

### Mast assemblies

- Sellick Roller design.
- Corrosion resistant lift chain.

### Tires

- Standard 31" all terrain tires for all job sites.

### Electrical

- Voltage: 12 V; alternator: 80 A; battery: 875 CCA.
- Sealed ECU and fuse box.
- LED brake and reverse lights for transporting.

### Mounts

- Universal easy-to-install mounts fit most trucks/trailers.

### Standard Features

- Electrical light cord
- Parts CD
- Halogen lighting includes regular and four way mounted lights.
- Safety lighting LED brake/amber warning lights.
- Spring applied, hydraulic release park brake.

### Optional Equipment

- Tilt steering column
- Strobe light
- Custom paint
- Cold weather package



# STM55-4W STM55P-4W

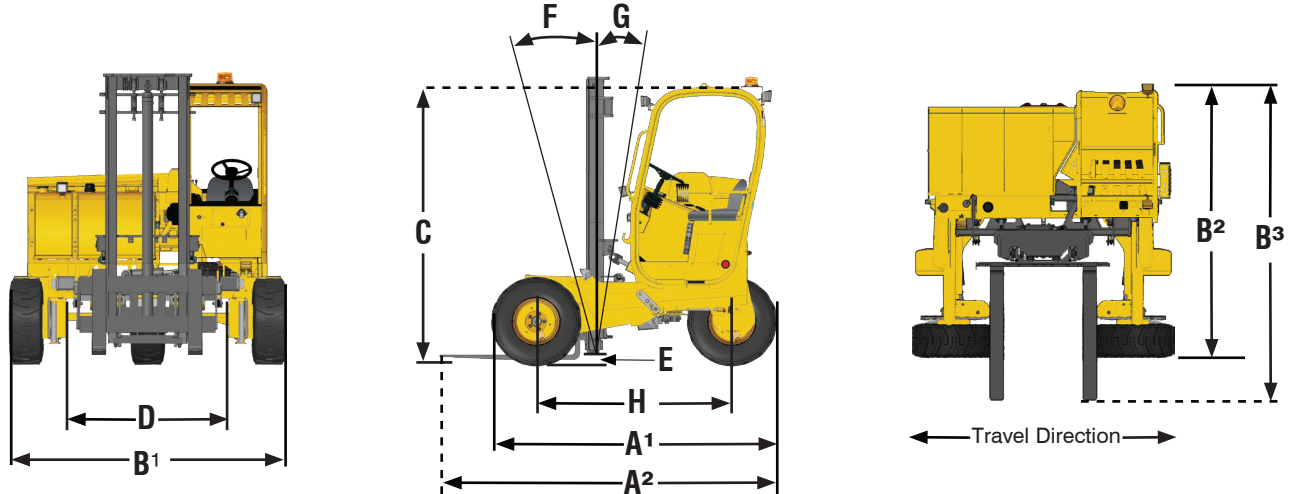

Specification	Ref	STM55-4W	STM55P-4W
Lift capacity @ 24" load centre		5500 lbs / 2495 kg	5500 lbs / 2495 kg
Operating weight w/ 144" mast (without forks)		8285 lbs / 3758 kg	9475 lbs / 4298 kg
Overall length (without forks)	A <sup>1</sup>	99" / 2515 mm	107" / 2718 mm
Overall length (with 48" forks)	A <sup>2</sup>	116" / 2946 mm	124" / 3150 mm
Minimum overhang		62" / 813 mm	70" / 1788 mm
Overall width (standard mode)	B <sup>1</sup>	101" / 2565 mm	101" / 2565 mm
Overall width without forks (4WAY mode)	B <sup>2</sup>	101" / 2565 mm	109" / 2769 mm
Overall width with 48" forks (4WAY mode)	B <sup>3</sup>	115" / 2921 mm	123" / 3124 mm
Height to top of OHG	C	98" / 2489 mm	
Frame opening	D	58.5"	
Outside turning radius (standard mode)		120"	
Mast sideshift		6" / 152 mm	
Mast underclearance	E	8" / 203 mm	
Mast tilt - forward	F	12 °	
Mast tilt - rearward	G	8 °	
Gradeability (standard mode)		25%	
Wheelbase	H	67 " / 1702 mm	75" / 1905 mm
Tire size		31.5 - 13 - 16.5 10 ply	
Engine build/model		Kohler KDI 1903TCR Tier 4 compliant	
Engine type		Diesel, turbocharged, electronic	
Cylinders		3	
Engine output		56 hp	
Transmission type		Hydrostatic	

Because of our constant dedication to product improvement, all specifications are subject to change without notice.

— All Sellick forklifts meet or exceed ANSI/ITSDF B56.14 - 2015 Safety Standard for Vehicle Mounted Forklift Trucks. —

**SELICK**  
**Sellick Equipment Limited**  
 P.O. Box 1000/358 Erie Street North  
 Harrow, Ontario, Canada N0R 1G0  
 519-738-2255 • sellick@mnsi.net  
 Visit us at [www.sellickequipment.com](http://www.sellickequipment.com)



Sold & serviced by: