

SELLICK

SLP Series



The Sellick SLP Series rough terrain forklift

Compact

Durable

Low Profile

Standard specifications

The low profile rough terrain SLP Series forklift is ideally suited for work in tight spaces. Featuring a proven drivetrain, tight turning radius, and ROPS/FOPS overhead guard, this forklift is an exceptional performer on any surface.



Engine

KOHLER KDI 2504 TCR Tier 4 engine does not require exhaust aftertreatment. Diesel Particulate Filter (DPF) and Diesel Exhaust Fluid (DEF) are not required reducing operating costs. Engine is equipped with fuel/water separator with hand primer, dual element air filter, air pre-cleaner, cold weather starting aid & vertical exhaust.

Transmission

Four-speed power reversing synchroshuttle transmission with torque converter and integral parking brake. 4-speed fully automatic transmission standard on 4WD models.

Axles

High load capacity drive & steer axles provide less wear and low maintenance. Limited slip differential provides increased traction.

Brake system

Enclosed multi-disc, oil-immersed service brakes with mechanically-operated, lever applied, parking brake.

Steering

Load sense power steering.

Instruments

Full instrument package includes warning indicator lights & gauges.

Mast assemblies

Sellick SEE-THRU® all-roller mast design. A wide range of two or three-stage available with maximum lift height up to 22 ft. Mast sideshift: 6" total.

Standard equipment

- Suspension seat w/seatbelt*
- 2 front & 2 rear halogen worklights
- LED brake & amber flashing lights
- Neutral safety start
- Tilt steering wheel
- Horn & backup alarm

*Suspension seat standard on 85" platform only

Optional equipment

- Fully enclosed cab with heat
- Hydraulic fork positioning
- AM/FM/MP3
- Cold weather package
- Solid cushion tires

SLP SERIES

TECHNICAL SPECIFICATIONS

Lift capacities of 5,000, 6,000 or 8,000 @ 24" load centre

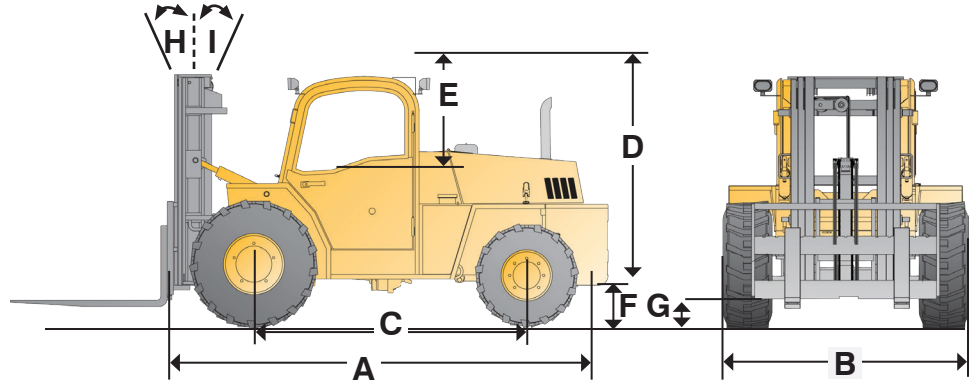

| Model | Ref | SLP50 | SLP60 | SLP80 |
|---------------------------------------|-----|--|--|---------------|
| Lift capacities @ 24 inch load centre | | 5,000 lbs | 6,000 lbs | 8,000 lbs |
| Total weight (w/2 stage mast) | | 11,000 lbs | 12,600 lbs | 13,700 lbs |
| Overall length (without forks) | A | 147"/3,734 mm | 147"/3,734 mm | 152"/3,861 mm |
| Overall width | B | | 78"/1,981 mm | |
| Wheelbase | C | | 93"/2,362 mm | |
| Height to top of overhead guard | D | | 75"/1,905 mm 85"/2,159 mm | |
| Distance from seat to OHG | E | | 40"/1,016 mm (75" OHG) 45"/1,143 mm (85" OHG) | |
| Outside turning radius | | in 2WD mode: 178"/4,521 mm; in 4WD mode: 196"/4,978 mm | | |
| Frame underclearance | F | | 11"/279 mm | |
| Mast underclearance | G | | 12"/304 mm | |
| Mast sideshift | | | 6"/152 mm | |
| Mast tilt - forward | H | | 20° | |
| Mast tilt - rearward | I | | 10° | |
| Gradeability | | | 25% | |
| Tire size | | | Drive: 15-19.5-12 ply Steer: 12-16.5-10 ply | |
| Engine manufacturer & model | | KOHLER KDI 2504 TCR - Tier 4 Final | | |
| Cylinders | | 4 | | |
| Engine output (gross power) | | 74 hp @ 2,600 rpm | | |
| Peak torque | | 221 ft-lbs @ 1,500 rpm | | |
| Travel speed | | 15(24) mph (km/h) | | |

Because of our constant dedication to product improvement, all specifications are subject to change without notice.

All Sellick forklifts meet or exceed all ANSI B56.6 safety standards.



Sold & serviced by:

